

Demo Case

Ordering Code: DEMO.C-SIZE3.DL.IP65.V1

Size: 300mm x 300mm x 85mm

Weight: ~1570g

SIZE-3 IP 65 DOWNLIGHT

REDUCED GLARE & PINHOLE DOWNLIGHT

Introducing our size-3 IP65 reduced glare and pinhole downlight fixtures demo case, designed for applications in wet areas. The modular concept design provides flexibility of different combinations with various LED module choices to fulfil application needs, while LED modules are upgradeable to ensure that your lighting solution is future proof. These IP65 downlights can also be fitted with multiple accessories options.

Experience the versatility and functionality of our size-3 IP65 downlight fixtures today.



Compatible LED Module



Module Colour Temperature Variation



Beam Angle

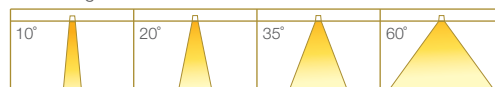

Driver Dimming Variation



SIZE-3 IP 65 DOWNLIGHT DEMO CASE

RECESSED FIX / TILT DOWNLIGHT LUMINAIRE



3-SERIES DEMO CASE INCLUSIVE OF:



REDUCED GLARE DOWNLIGHT

| | | Fixture | | | | | | | | | | |
|------------------------------|---------------------|--------------|---|-------|----|-------|----|--------|----|------------------|----|--------------|
| Type | | Trim Options | | Shape | | Angle | | Colour | | Reflector Colour | | |
| Modular PRO Selection | | | | | | | | | | | | |
| 1a | VASARI-3PRO-SL.IP65 | | T | Trim | RD | Round | TL | Tilt | WH | Matt White | CB | Chrome Black |
| 1b | VECO-3.IP65 | | T | Trim | RD | Round | FX | Fix | MB | Matt Black | CR | Chrome |

PINHOLE DOWNLIGHT

| | | Fixture | | | | | | | | | |
|------------------------------|----------------------|--------------|---|-------|----|--------|----|--------|----|------------|--|
| Type | | Trim Options | | Shape | | Angle | | Colour | | | |
| Modular PRO Selection | | | | | | | | | | | |
| 2a | ECLIPSE-3.IP65 | | T | Trim | RD | Round | TL | Tilt | WH | Matt White | |
| 2b | ECLIPSE-3PRO-SL.IP65 | | T | Trim | SQ | Square | TL | Tilt | WH | Matt White | |

CONNECTION DIAGRAM

ELR Modular Concept

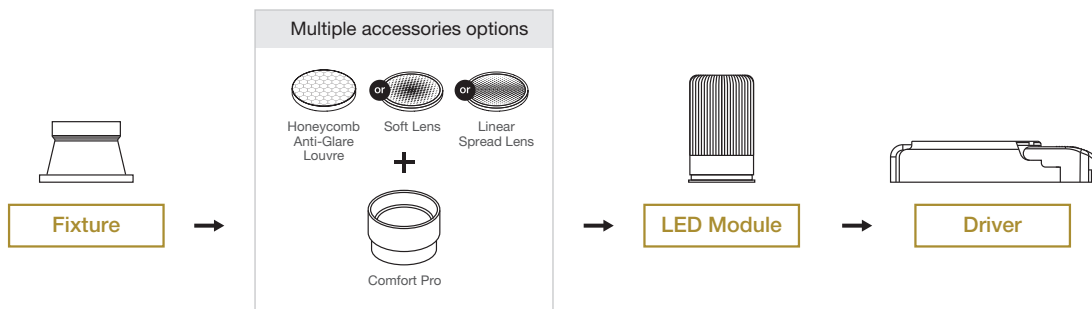

Constant Current - Integrated Driver

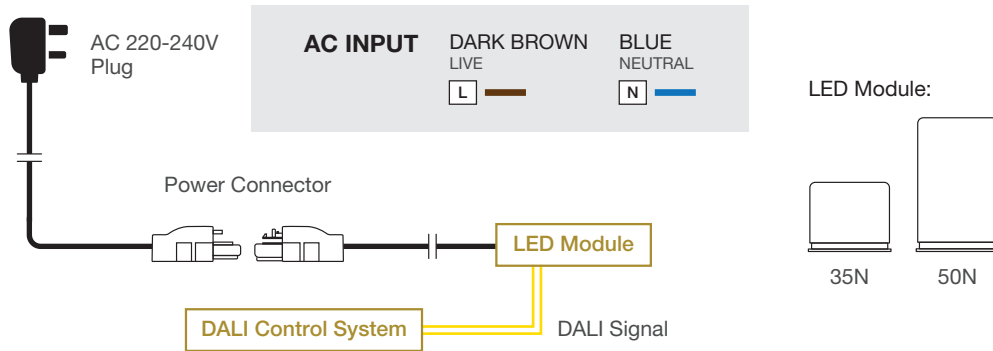

CONNECTION DIAGRAM

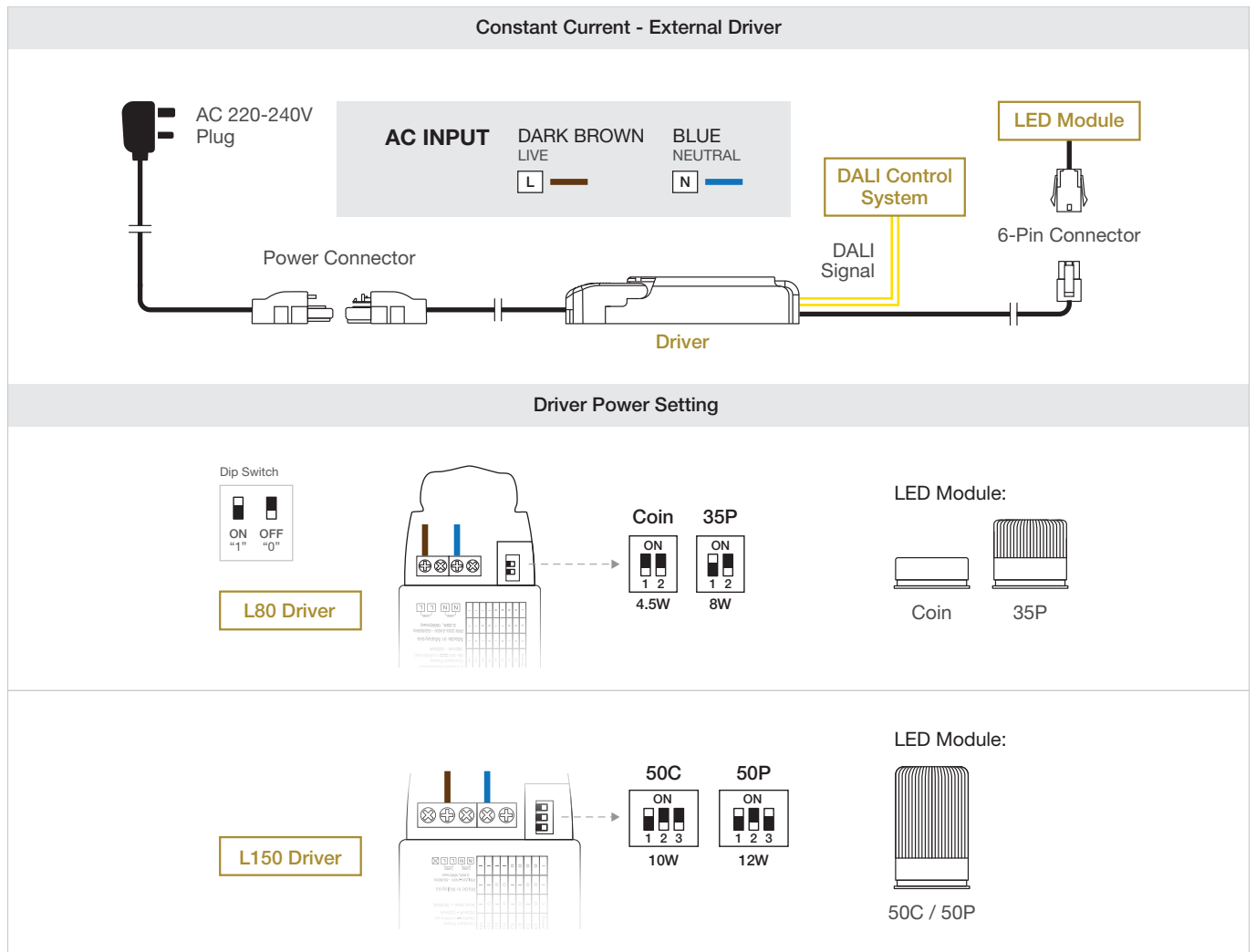

INSTALLATION GUIDE - CEILING SAFE

LED module replacement / maintenance

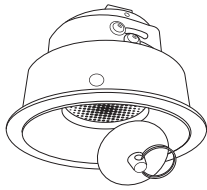

Reduced Glare

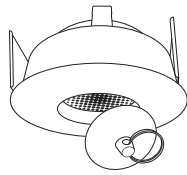

Pinhole

1. Place and press the suction cup firmly to the glass surface.

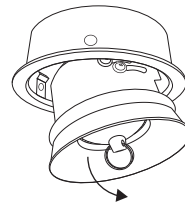

Reduced Glare

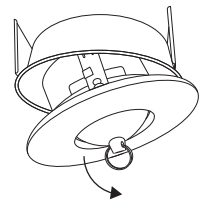

Pinhole

2. Hold the ring on suction cup and pull it. The module holder will detach from fixture frame.