

**!** CEILING THICKNESS 5MM ~ 20MM

**⚡** PLEASE MAKE SURE THAT MAINS IS DISCONNECTED BEFORE PROCEEDING!

Follow the steps as illustrated below

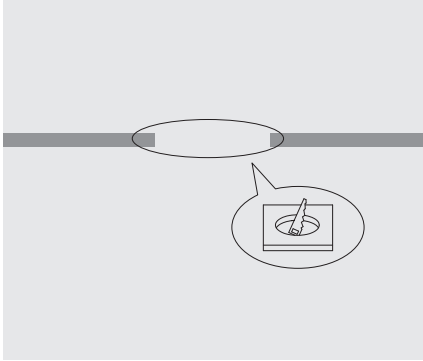

1. Cutout.

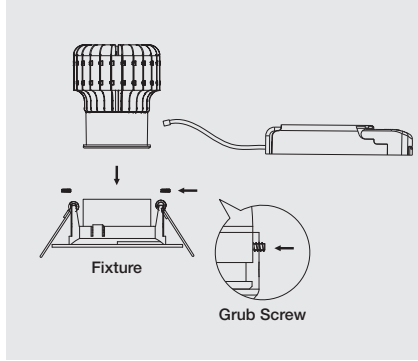

2. Grub screw to tighten between module & fixture and connect module to driver.

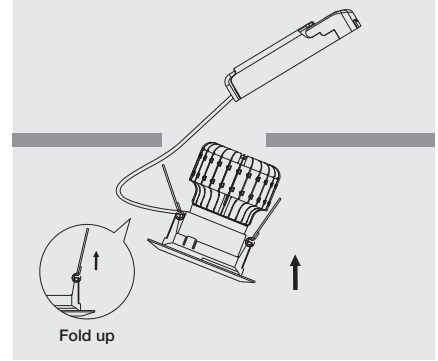

3. Fold up the spring clips and gently insert one side of the fixture into the cut out hole.

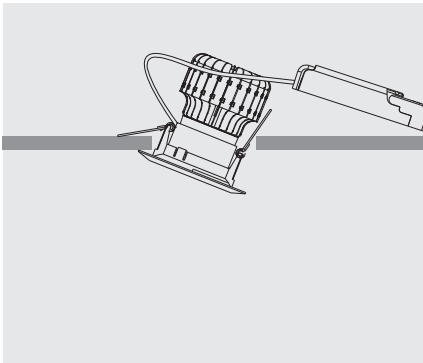

4. Secure the fixture by pushing in the other side.

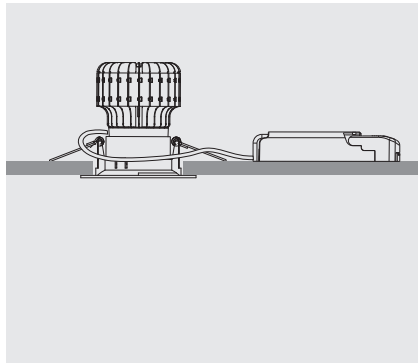

5. Installation complete.

For connection between ELR LED modules and drivers, please refer to LED Module Installation Guide.

**SAFETY WARNING**

- Luminaires MUST be installed by licensed electrician in accordance with local standards.
- LED modules MUST ONLY be connected to supplied LED drivers. It is not compatible with any other type of driver. Failure to adhere to this may cause damage and void warranty.
- DO NOT COVER lamp or driver under any circumstances.
- Ensure mains supply is not energised and/or is disconnected prior to installation/ connection/disconnection of LED module from LED driver.
- Luminaires must not be Megger tested or connected during any in-circuit testing.
- No user serviceable parts. Do not attempt to disassemble or repair lamp or driver.
- Do not use in flammable or explosive environments.
- Do not attempt to modify luminaires or supplied wiring in any way.
- Allow suitable air flow and ventilation around the luminaire.

**DIMMER COMPATIBILITY DECLARATION**

Our Luminaires are designed for industry and home commonly used standard phase dimmers for best lighting effect achievement to provide added value to customers.

However, with thousands of dimmer models available in the market today, 100% compatibility cannot be guaranteed. In order to avoid disappointment, it is advised to use dimmer models that have been tested to be compatible. The latest information on dimming compatibility is available within our Dimmer Compatibility Card and can be obtained through our website and local distributors.

If any intended dimmer model to be used is not listed in our Dimmer Compatibility Card, kindly contact us and send in the dimmer to be tested. We will respond within the shortest possible time and advise on the compatibility with our luminaires.

We will not be responsible for all losses due to the incompatibility of the dimmer with our luminaires. Incompatibility includes abnormal operations i.e., flicker, throb, delayed on/off, failure, narrow dimming ranges, etc. and are not limited to the above mentioned conditions.